

Selection Information

General

Racor Turbine Series Fuel Filter/Water Separators have been protecting engines from water, dirt, foulants and other contaminants for over 30 years using a patented three-stage process:

- 1. Separation.** The turbine centrifuge separates solids and 'free' water through centrifugal action. Although the turbine has no moving parts, over 30% of the contaminants are removed here.
- 2. Coalescing.** Smaller water droplets and solids coalesce on the specially designed conical baffle and fall to the collection bowl.
- 3. Filtration.** Engines benefit from near 100% water separation and fuel filtration with Racor's proprietary Aquabloc™ water repelling media.

The units are designed for installation on the suction (vacuum) side of the fuel transfer pump for best efficiency but may be installed on the pressure side up to 15 PSI.

Filters:

High-capacity Aquabloc™ replaceable cartridge elements stop water and remove solid contamination and are available in 2, 10 or 30 micron. Boat owners can specify their filtration needs based on application, fuel quality, operating climates and maintenance schedules.

A 30 micron filter (or primary filter) is used to filter raw fuel (or poor quality fuel) before it can be further filtered by finer medias such as a 10 or 2 micron. A 10 micron filter (or secondary and even final) is used to filter fuel which is known to be of good quality. A 2 micron filter (or final filter) is the finest filtration available and is the last filter used prior to engine ingestion.

A simple rule to remember is the finer the filtration, the more frequent the filter change. (*Carry extra filters on board*).

Collection Bowls:

The see-thru bowls used with these models won't discolor from alcohol, additives or UV light and feature NPT tapered thread plug for removing contaminants. An optional UL Listed shut-off drain valve may be ordered to simplify servicing. For gasoline or severe service in diesel applications, specify metal bowls, only.

Options -Available for Diesel fuel systems only.

Water Probe RK21069. All units may be ordered with an in-bowl water probe to alert the operator of a high-water condition, even while the equipment is operating. The bowl is then drained of water at the earliest convenience. Note: A Racor Water Detection Module is needed to work with this probe. See Accessories.

Water Probe RK30880. Same features as above, except the 12 or 24 vdc electronic detection module is built-in the probe housing. Includes a detachable connector. See Accessories.

Accessories

The condition of the filter may be monitored using a vacuum restriction gauge. See the Accessories Section.

SELECTION

1. Along with the information you obtained in SECTION 2, SELECTION (page 94), consider the following:
Are there any space limitations in the available location? The location should provide adequate overhead space for removing the element and underneath space for draining off contaminants from the bowl.
2. What filtration rating is needed? 2, 10 or 30 micron?
3. What options are needed? Water probe and/or a bowl shut-off drain valve?
4. Can the engine be shut down for servicing?
For engine(s) that cannot be shut-down if servicing becomes necessary, specify only MAV or MAX units.

Using this information, select a unit from the following page for your application.

For additional information, call your Racor dealer or call Racor customer service at (209) 521-7860 or (800) 344-3286, 6:00 AM to 5:00 PM, Pacific Time, or e-mail us from our website, www.parker.com/racor.

Model Illustrations

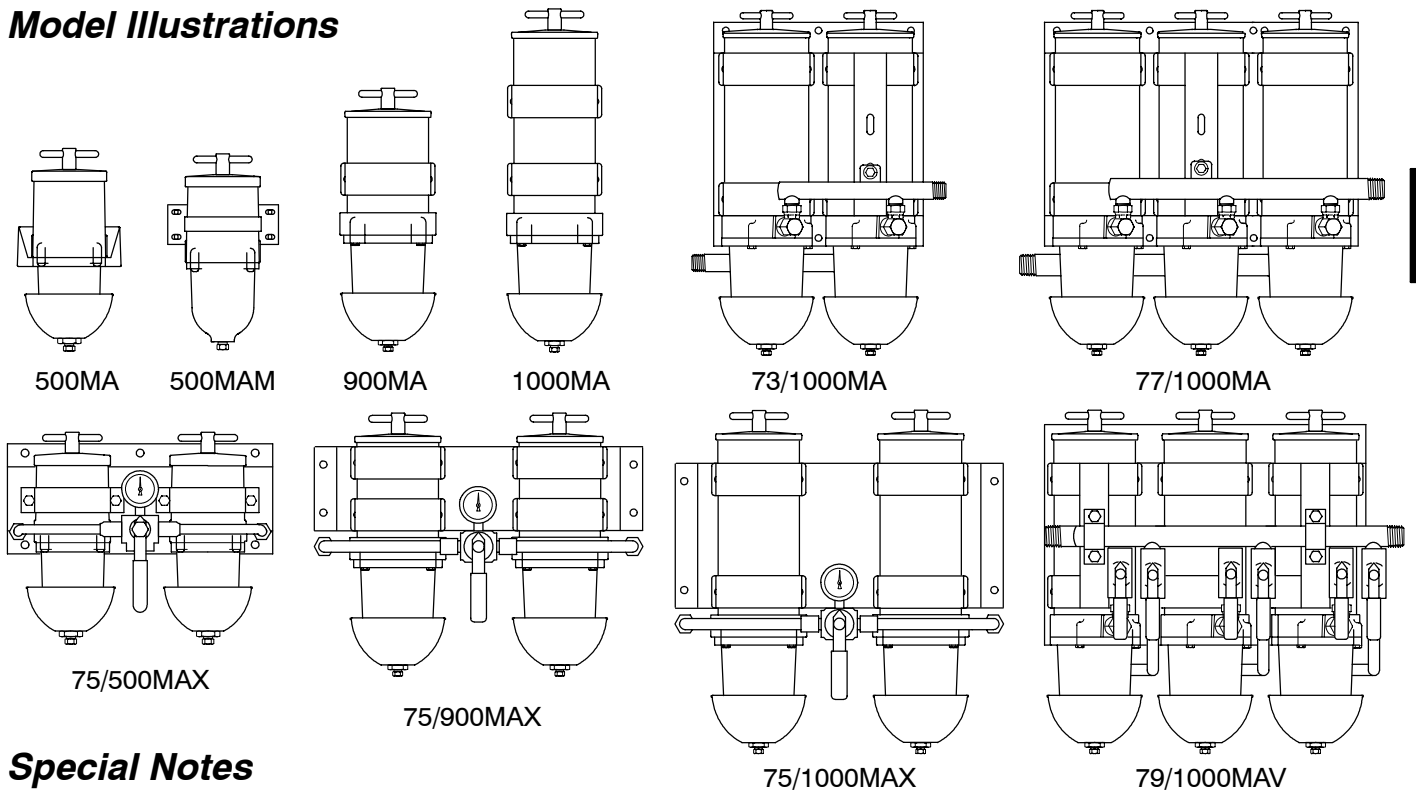

Special Notes

1. See-thru bowl MA / MAX / MAV units are approved for Diesel service only. UL Listed, USCG Accepted.
2. Metal bowl MAM / MAXM units are approved for Gasoline and Diesel service. UL Listed, USCG Accepted.
3. For additional info. and availability, contact customer service at: (800) 344-3286, 6 AM to 5 PM, Pacific Time.



Specifications

BASIC MODELS		500MA	900MA	1000MA	73/1000MA	75/500MAX	75/900MAX	75/1000MAX	77/1000MA	79/1000MAV
Maximum Flow Rate	GPH	60	90	180	360	120	180	360	540	540
	LPH	227	341	681	1363	454	681	1363	2044	2044
Port Size		3/4"-16 ^{1,2}	7/8"-14 ¹	7/8"-14 ¹	3/4"-14 ³	3/4"-16 ¹	7/8"-14 ⁴	7/8"-14 ⁴	1"-11 1/2 ³	3/4"-14 ³
Filter Element		2010 Series	2040 Series	2020 Series	2020 Series	2010 Series	2040 Series	2020 Series	2020 Series	2020 Series
Height	in./mm	11.5/292	17/432	22/559	22/559	11.5/292	17/432	22/559	22/559	22/559
Width	in./mm	5.8/147	6/152	6/152	16.5/419	14.5/368	18.8/476	18.8/476	21.5/546	21.5/546
Depth	in./mm	4.8/122	7/178	7/178	12/305	9.5/241	11/279	11/279	12/305	11.8/300
Weight	Lbs./kgs.	4/1.7	6/2.7	10/4.5	26/11.8	17/7.7	23/10.4	30/13.6	39/17.7	52/23.6
Clean Pressure Drop	PSI	0.25	0.34	0.49	1.7	0.70	1.7	3.7	1.7	2.5
	kPa	1.72	2.4	3.4	11.7	4.83	11.7	25.5	11.7	17.2
Max. Allowable Pressure	PSI	15	15	15	15	15	15	15	15	15
	kPa	103	103	103	103	103	103	103	103	103
Bowl Water Capacity		ml	110	305	305	610	220	610	610	915
Overhead Clearance ⁵	in.	4	5	10	10	4	5	10	10	10
	mm	102	127	254	254	102	127	254	254	254
Operating Temperature		- 40° / +255° F / - 40° / +121° C								

¹ SAEJ1926 O-ring boss ² Effective 1/15/96, call factory for other sizes. ³ SAEJ476 (NPT) National Pipe Tapered thread
⁴ SAEJ514 (JIC) Joint Industry Council, 37° male flare ⁵ Required for element removal / servicing.

SPECIFICATIONS are found on Turbine Series introduction page.

How to Order -The example below illustrates how the part numbers are constructed.

500MA	P	10
Basic Model 60 GPH Add 'M' for metal bowl Example: 500MAM	Water Probe. ¹ Add 'P' for an in-bowl water probe. (Omit if not desired).	Element Filtration Rating. Specify one: '2' for 2 micron '10' for 10 micron or '30' for 30 micron
¹ Must be used with Water Detection Kit. See Accessories Section.		

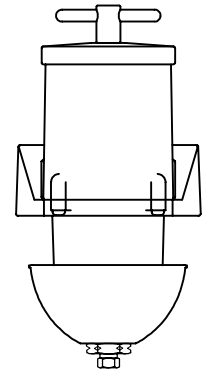

500MA

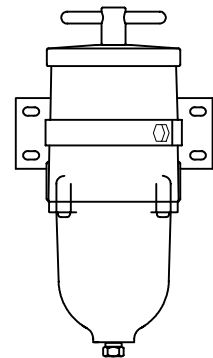

500MAM

Replacement Service Elements -For all Model 500 Series
 SERVICE ELEMENT INCLUDES LID SEAL AND T-HANDLE O-RING.

2010SM-OR	2 Micron (Brown end caps) Recommended for Final /Secondary Filtration
2010TM-OR	10 Micron (Blue end caps) Recommended for Primary or Secondary Filtration
2010PM-OR	30 Micron (Red end caps) Recommended for Primary Filtration* Only. *A secondary/final filter is required downstream.

Mounting Hole Patterns -Refer to Turbine Series introduction page for filter dimensions.

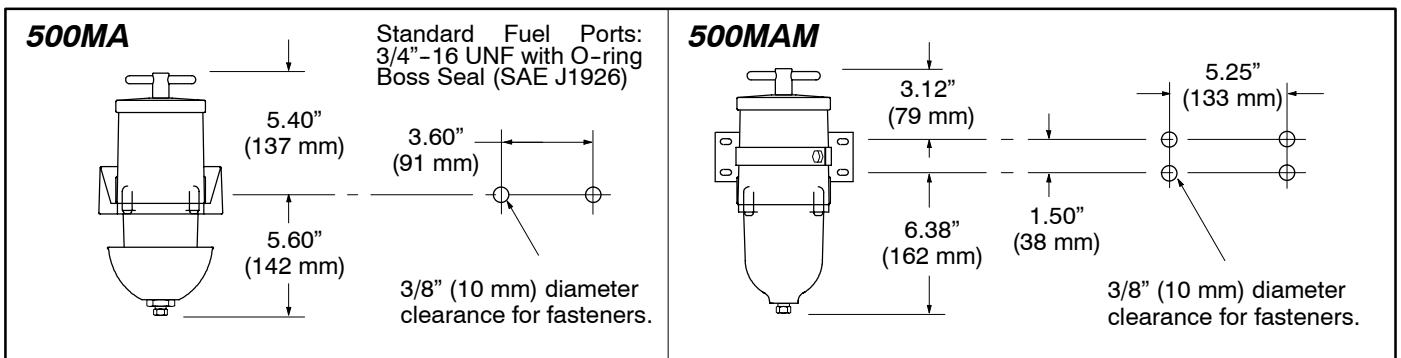

Performance Graphs -These results are from controlled laboratory tests. Field results may vary by application.

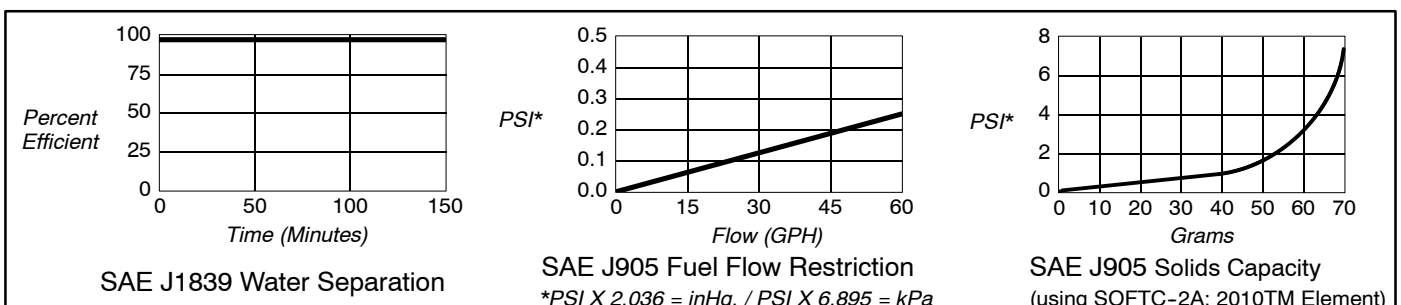
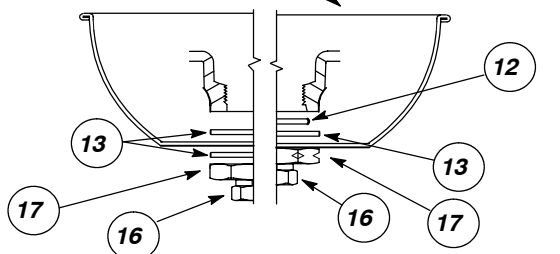
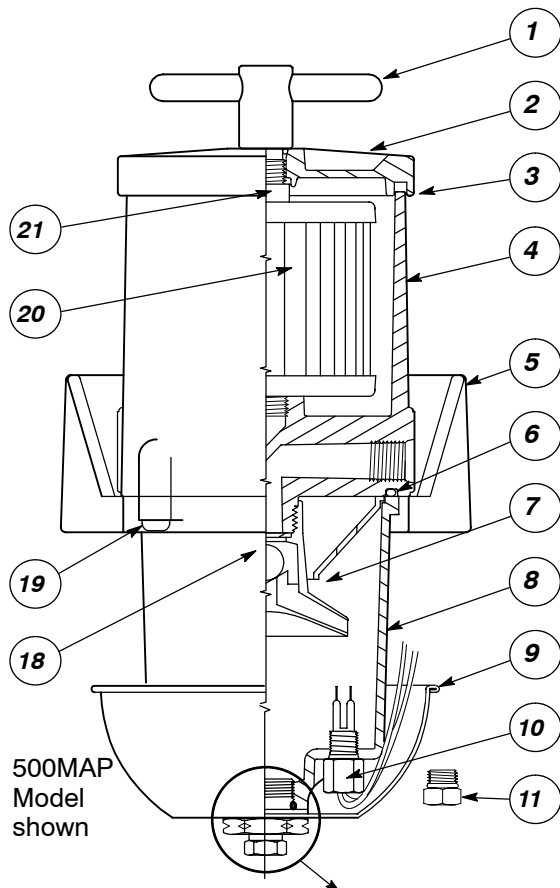
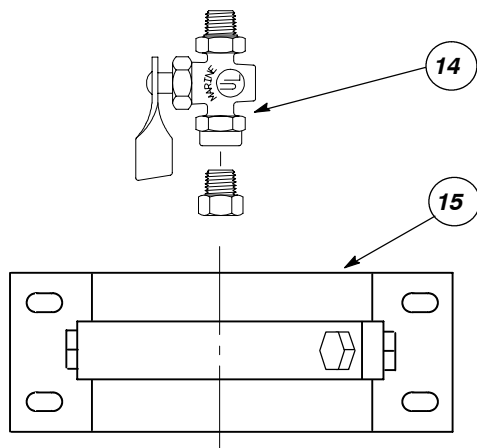

FIGURE 1. 500MA Series Cutaway View. The circled number corresponds to the item number shown below.



Old Style⁴ New Style
Drain Fitting Configurations



500MAM 3-Piece Bracket

Item	Part No.	Description	Case Qty.
1	RK11888	T-handle	1
	11350	T-handle O-ring	10
2	RK15078	Lid	1
3	15005	Lid Gasket	10
4	RK15377-01	Body, 3/4"-16 UNF Ports (MA, effective 1/15/96)	1
	RK15082	Body, 9/16"-18 UNF Ports (prior to 1/15/96)	1
5	RK15090	Mounting Bracket, unitized with Bowl Ring (MA)	1
6	15374	Bowl Gasket (supercedes 15009 O-ring-All models)	10
7	RK15013D	Turbine Centrifuge / Conical Baffle	1
8	RK15279-01	See-thru Bowl w/ Water Probe Plug, (MA)	1
	RK15301-01	Metal Bowl w/1/4"NPT Drain & Water Probe Port	1
9	RK15104 ¹	Heat Deflector Shield (MA)	1
10	RK21069 ²	Water Probe Assembly	1
11	RK20022	Metal Water Probe Port Plug	1
12	11340	Drain Fitting O-ring (New Style)	1
13	11041	Bowl Drain Washer (New and Old Style)	10
14	RK19492	Diesel Marine Shut-off Valve Kit.	1
15	RK15300	Mounting Bracket, 3-piece (MAM)	1
16	918-N4	Bowl plug, 1/4" NPT (Old and New Style)	1
17	11-1910	Bowl Drain Fitting (New Style)	1
	RK11-1910	Complete Bowl Drain Fitting Kit (New Style)	1
	11040	Bowl Drain Fitting (Old Style)	10
18	RK15010B	Check Ball w/ Seal	1
19	RK15081-01 ³	Phillips Head Capscrews 10-24 x 1" (4)	1
	RK15081 ³	Hex/Washer Head Capscrews 10-24 x 7/8" (4)	1
20	2010SM-OR	2 Micron Element w/ Seals	12
	2010TM-OR	10 Micron Element w/ Seals	12
	2010PM-OR	30 Micron Element w/ Seals	12
21	RK15079	Return Tube (w/ tapered pipe base threads)	1
22	RK15211	Seal Service Kit (all models- not shown)	1
	15335	Installation Instructions, 500MA	

1 For replacement only. The Coast Guard does not accept 'FG' units converted to 'MA' configurations.
 2 For diesel service only. Must be used with a Water Detection Kit.
 3 Models built prior to 2/96 use RK15081-01, after 2/96 use RK15081. (Fuel ports have 1 1/4" square boss on models made after 2/96).
 4 Units built prior to Fall, 1998.
 See Accessories Section.

